



Smart Topology Quick Facts

- Topology is also known as:
Collapsed Core
Collapsed Backbone
- Simple Operations and Management
- Rapid deployment
- Secure
- Available as a service, as a product set or as a combination
- Engineering Support Available
- Used for fluid edge of critical networks, SCADA/DCS, remote maintenance, Telco Access Circuits, DR, backup and many others
- When to use Layer-2 and when to use Layer-3?
- Rugged hardware

FastL2® Smart Topology for the Edge

Use a Layer-3 Collapsed Core with Layer-2 Transparent Ethernet Circuits over Any IP Network to Edge Sites

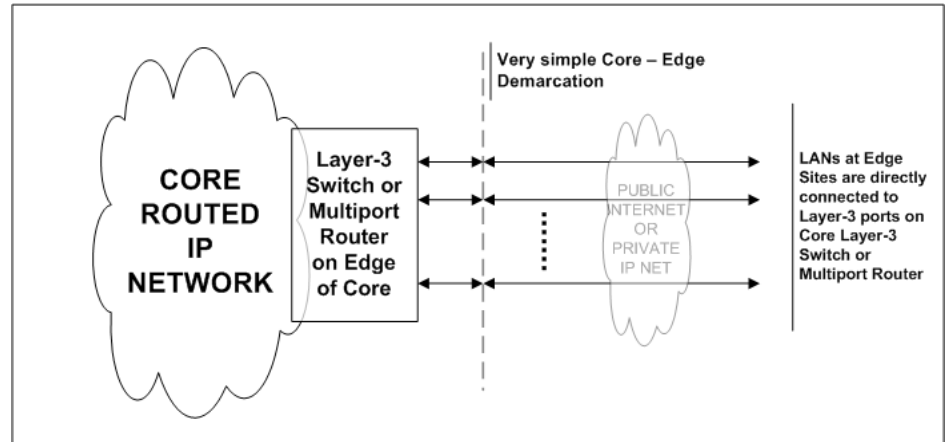

Topology is also known as Collapsed Core or Collapsed Backbone

This network topology has a long history dating back to FDDI in the 1990s. It has always been a good option for reducing capex and opex costs and for simplifying the management and operation of the edge of complex networks.

This type of topology keeps the complex network elements such as routers and security perimeters in the physical core of the network and uses simple transparent Layer-2 Ethernet circuits to LANs at edge sites.

Using FastL2® the edge sites can be rapidly deployed to any Internet-connected location – which nowadays means anywhere via DSL, Cable, Satellite, Cellular and others.

Simple Operations and Management

Organizations that have significant

edge networks – such as Industrial, Maintenance, Military, Construction, Oil & Gas – are familiar with the reality that 5% of your network (the edge) can consume 50% of your operations and management (O&M) effort.

Using a Smart Topology with FastL2® creates a very simple, clear core/edge demarcation and allows all the standard Network Management and Test & Measurement tools to be deployed at the physical core where people are available.

For large-scale deployment the Smart Topology shown above can be made even smarter by the use of VLAN trunks so the entire network edge is connected to one or more VLAN trunks.

Rapid Deployment

The core network, up to the demarcation, can be pre-provisioned and tested. Then, when the FastL2® hardware appliance is available at the remote site, the service is usually up and running in minutes.



Products and Services for Mission Critical Networks

Secure

Many Edge networks rightly include perimeter security for Authentication, Firewalling and Policy Enforcement.

In our experience these can usually all continue as an inner security perimeter located at the Core/Edge demarcation at the physical core of the network.

In addition, FastL2[®] itself is highly secure and can provide an additional outer security perimeter so that malicious users cannot even access the inner perimeter.

Service, Product or Combination

FastL2[®] is available as a pure service with rented appliances and the use of one of our multiple global YR20[®]-operated FastL2[®] hub PoPs currently located in US-East, US-West, US-South, EU-West and AsiaPacific.

FastL2[®] is available as a product set to be owned and operated by the customer with the FastL2[®] hub PoPs located in the customer's datacenter facility.

Service and product arrangements can be combined in a number of ways to suit a customer's technology and business needs and preferences for capex, opex, in-sourcing and out-sourcing.

Engineering Support Available

We have a team of very experienced network engineers, located in the USA and Europe, who can work with you to identify IF, and if so, HOW, a Smart Topology including FastL2[®] could benefit the edge of your network.

YR20 was formed in 2001 to address the engineering, commissioning and maintenance issues associated with the Oil & Gas industry using TCP/IP networks for critical traffic. The company has now worked for over 50 Oil & Gas operating and supply companies to engineer, commission, and maintain critical networked IT systems. YR20 has the necessary products, tools, and personnel ready for worldwide deployment in any challenging network or industrial environment.

For more information please contact:

YR20 (UK) LTD

+44 (1224) 766-646

Westpoint House, Prospect Road

Westhill, Aberdeenshire AB32 6FE

doug.stevenson@yr20.com or www.yr20.com

YR20 US LLC

+1 (832) 225-1293

1718 Fry Road, Suite 440

Houston, TX 77084

mike.hinz@yr20.com or www.yr20.com

What is FastL2[®] Used For

FastL2[®] is used in a variety of ways.

Telcos can use FastL2[®] for off-net access circuits, for urgent requirements where the normal 60-90 day provisioning is not acceptable, for DR services and for circuit backup.

Corporations can use FastL2[®] for secure SCADA/DCS industrial networks over commodity Internet or private IP networks, for remote maintenance of assets, for mobile sites such as vehicles, construction sites and for traveling teams.

When to use Layer-2 and when to use Layer-3?

Building an optimum network involves using Layer-2 (Ethernet switching and bridging) and Layer-3 (IP routing). Many organizations have built sub-optimal networks by using Layer-2 for large-scale mesh WANs or pushing the entire Layer-3 infrastructure to large numbers of stub WAN sites.

The Smart Topology with FastL2[®] is intended to use Layer-2 and Layer-3 to their best effect.

If our engineers are involved they will provide impartial advice on whether, and how, to use a Smart Topology with FastL2[®].

Rugged Hardware

The FastL2[®] appliances were developed for rental to mobile and industrial customers and were first deployed in the the offshore Oil & Gas industry. Accordingly the FastL2[®] Appliances are small and ruggedized.

©2010 YR20. All rights reserved. PCAP-Probe and FastL2 are registered trademarks and the YR20 logo is a trademark of YR20 and/or its affiliates in the United States and/or the UK. All other brands and product names and registered and unregistered trademarks are the sole property of their respective owners. YR20 reserves the right, at its sole discretion to make changes at any time in its technical information, specifications, and service and support agreements.

Nov. 2010

